



**INSTALLATION, USE AND  
MAINTENANCE MANUAL**

Information Note

# **SDFLEX**

## **VERTICAL LINE: GUIDED TYPE FALL ARREST INCLUDING A RIGID ANCHOR LINE**

EN 353-1+A1:2017



Rev05\_06.26

## **MANUFACTURER DETAILS**



### ***Sicur Delta S.r.l. con socio unico***

*Via A. Vespucci, 16 - 56029 - S. Croce sull' Arno (PI)*

*Tel. +39 0571 33588, Tel. +39 0571 367677, Fax. +39 0571 367599*

*Share Capital €115,000.00 fully paid up, Tax Code and VAT No. 05738810489*

*Business Reg. of Pisa 05738810489, R.E.A. PI – 158714*

*[info@sicurdelta.it](mailto:info@sicurdelta.it)*

*[www.sicurdelta.it](http://www.sicurdelta.it)*

*For questions, technical insights and any other  
need, please contact the manufacturer using the details above*

*It is forbidden to reproduce this manual even partially  
without previous authorisation from Sicur Delta Srl*

SICUR DELTA S.r.l. is a company with UNI EN ISO 9001 Quality Management System and certificate for Extended Quality Requirements for Welding UNI EN ISO 3834-2.

## CONTENTS

<b>1</b>	<b>GENERAL INFORMATION .....</b>	<b>4</b>
1.1	Introduction .....	4
1.2	General Instructions .....	5
<b>2</b>	<b>USE.....</b>	<b>6</b>
2.1	Before each use .....	6
2.2	Characteristics of the anchoring device .....	7
2.3	SDFENAV installation .....	9
2.4	Prohibited uses .....	10
<b>3</b>	<b>MARKING .....</b>	<b>11</b>
3.1	Marking .....	11
<b>4</b>	<b>INSTALLATION INSTRUCTIONS.....</b>	<b>13</b>
4.1	Installation recommendations.....	13
4.2	Assembly and installation methods .....	13
4.2.1	Installation inferior element SDFEINF .....	14
4.2.2	8 mm diameter SDFCAVO cable assembly with SDFTEND tensioner .....	15
4.2.3	Assembly of SDFTEND tensioner to SDFEINF bottom bracket element .....	16
4.2.4	SDFESUP top anchor installation .....	16
4.2.5	SDFSERR cable clamp kit assembly.....	17
4.2.6	SDFESB2 upper anchor installation .....	18
4.2.7	SDFSERP cable clamp component assembly.....	20
4.3	SDFEINT intermediate element installation .....	21
<b>5</b>	<b>ROUTINE INSPECTION, MAINTENANCE AND SERVICE LIFE .....</b>	<b>23</b>
5.1	Routine inspection.....	23
5.1.1	Documentation Check and Inspection Deadlines.....	24
5.1.2	Visual inspection and Device Condition.....	24
5.1.3	Functional and/or instrumental checks on the device (s). .....	24
5.2	Maintenance .....	25
5.3	Service life .....	25
<b>6</b>	<b>PACKAGING, STORAGE, TRANSPORTATION .....</b>	<b>26</b>
<b>7</b>	<b>WARRANTY .....</b>	<b>26</b>
<b>8</b>	<b>SDFLEX VERTICAL LINE COMPONENTS.....</b>	<b>27</b>
8.1	Rope grab – SDFANEV.....	29
8.2	Lower anchorage .....	30
8.3	Upper anchorages.....	32
8.4	Upper anchorage with outreach section .....	34
8.5	Intermediate element .....	36
8.6	CABLE .....	37
8.7	FIXING SCREWS .....	37

# 1 GENERAL INFORMATION

## 1.1 Introduction

The personal protective equipment against fall from height SDFLEX, designed and built by the company Sicur Delta, is a **fall from height protection device**.

The SDFLEX device allows access to the work site at height via a fixed ladder preventing the operator from falling during ladder ascent/descent. Personnel accessing the workplaces at height to carry out maintenance operations will be able to do so in complete safety using the appropriate personal fall protection devices provided. Please note that these operators must be informed and trained in the use of fall arrest category III PPE.

This notice must always be available and accessible by the user. Any activity at heights is dangerous and can cause accidents, serious injury or death. Practice, as well as learning techniques for using the appropriate equipment are your responsibility.

The SDFLEX is conform to the harmonised standard **EN 353-1+A1:2017** and to the **PPE Regulation 2016/425/EU**.

The UE examination type and Module C2 control is conducted by the following notify body:



The EU declaration of conformity is provided with the PPE and it can be downloaded from the website [www.sicurdelta.it](http://www.sicurdelta.it).

You must carefully read and study this manual and full understanding before using the PPE. It is important to keep this manual for the entire life of the device as it is an integral part of it. In case of loss, this document can be viewed and downloaded from the website [www.sicurdelta.it](http://www.sicurdelta.it) or contact the manufacturer for a digital or hard copy.

## 1.2 General Instructions

**It is essential for the safety of the user that if the product is re-sold outside the original country of destination the reseller shall provide instructions for use, for maintenance, for periodic examination and for repair in the language of the country in which the product is to be used. These documents can be provided on request by contacting the manufacturer.**

To use SDFLEX safely, the user must be trained and competent, must be physically healthy and not under the influence of alcohol or drugs.

The use of SDFLEX is formally prohibited if the product is improperly installed or damaged. It should not be used beyond its limits or in any situation other than the one for which it is intended.

Any modification of the equipment, any addition to the equipment and any repair are totally forbidden, any repairs must be carried out in accordance with the operating procedures of SICUR DELTA.

Before any use of the SDFLEX, a rescue plan must be put in place to deal with any emergency that may occur during labor. It should, of course, be considered before and during use that this potential rescue be carried out effectively and safely.

Before each use check that all security elements are in good condition because the security function of one item is affected by the security function of another item or may interfere with it.

Should doubts or questions arise at any stage (design, installation, user manual...), do not proceed further and contact the manufacturer. Sicur Delta is not liable for damage, losses, or accidents resulting from incorrect use or interpretation of the data. No liability shall be borne for defects not attributable to the manufacturer. 021

## 2 USE

### 2.1 Before each use

**It is essential to check the required free space under the user in the workplace, so that in the event of a fall, there is no collision with the ground, no other obstacle set on the path of the fall.**

**It is essential for safety reasons that the anchor device is always properly positioned, and the work is done in such a way as to minimize the risk of falls and the height of the fall.**

Before any intervention the user must check:

- That the SDFENAV guided type fall arrester and his connector and the full body harness are in good condition.
- The energy absorber is not deployed.
- The connector closes automatically.
- The SDFENAV must move easily on the cable when moved upwards.
- The SDFENAV must automatically lock on the cable under a manual downward action.
- The fasteners and the lower end stop are undamaged and secured.
- The cable has no defects or torn failures.
- The rigid anchor lifeline is stretched correctly.

**it is essential for safety that equipment is withdraw from use immediately if:**

**1) any doubt arises about its condition for safe use or;**

**2) it has been used to arrest a fall and not used again until confirmed in writing by a competent person that it is acceptable to do;**

The SDFLEX should not be used beyond its limits, or in any situation other than the one for which it is intended, i.e. stop a fall. It should only be used by a trained person, competent in good physical shape, not subject to vertigo and not under the influence of alcohol or drugs for safe and emergency normal use.

## 2.2 Characteristics of the anchoring device

Guided type fall arrester  
SDFENAV

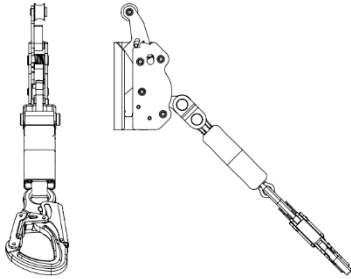

SDFLEX VERTICAL LINE WITH OR  
WITHOUT OUTREACH SECTION

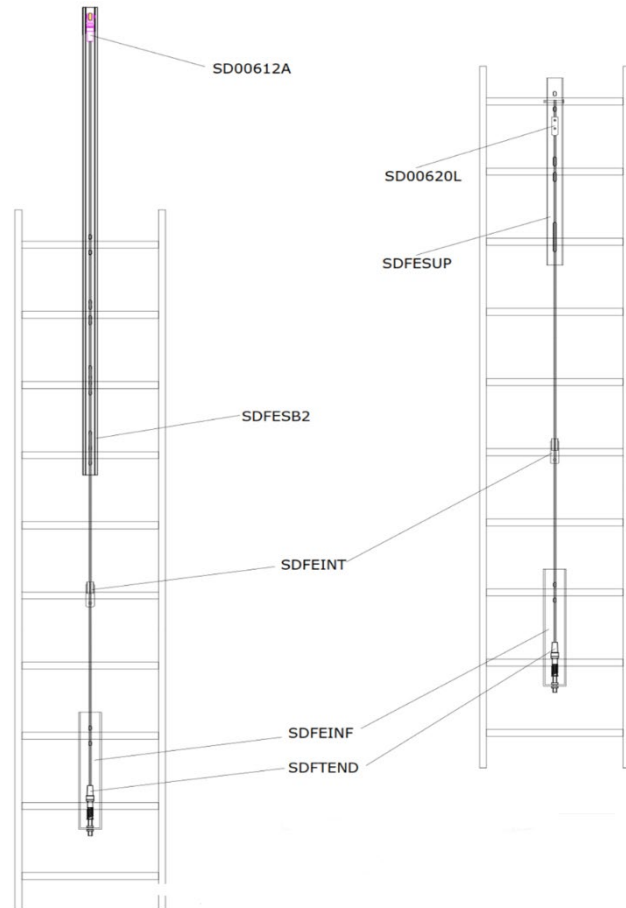

**Important:** Being tested and certified together, only the guided type fall arrester SDFENAV is allowed on the rigid anchor line SDFLEX.

Number of user allowed	1
Sideway leaning angle allowed	5°
Forward leaning angle allowed	5°
Minimum rated load without tool and equipment	50 kg
Maximum rated load included tool and equipment	100 kg
Effort transmitted parallel to the structure in case of a fall	6 kN
Minimum temperature of use	-30°C
Maximum span allowed	10 m
Tension of the rigid anchor line	0.5 kN

The SDFELX is designed to be installed on a ladder, with a minimum strength of the rung at 12 kN. During the ascent or descent, the SDFENAV guided type fall arrester slides freely on the cable. In the event of a fall, the locking cam blocks the cable against the body of the SDFENAV guided fall arrester and stops the fall. For safety, all points in the rigid anchor line at which the fall arrester could exit the rigid support are equipped with end stop.

UPPER ANCHOR POINT

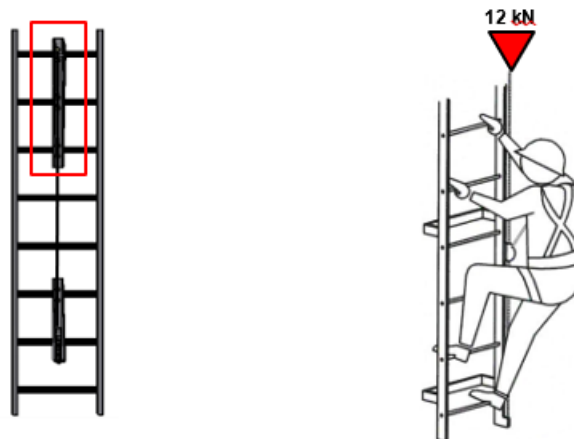

The user must be equipped with a full body harness conforms to the standard EN 361, the only acceptable body holding device that can be used in a fall arrest system. The full body harness should be properly adjusted (according to the instruction from the manufacturer) to a snug fit and should not be used if loose.

The SDFENAV must be connected to a front fall arrest attachment point of the full body harness noted "A" or to "A/2", two attachments loops to link.

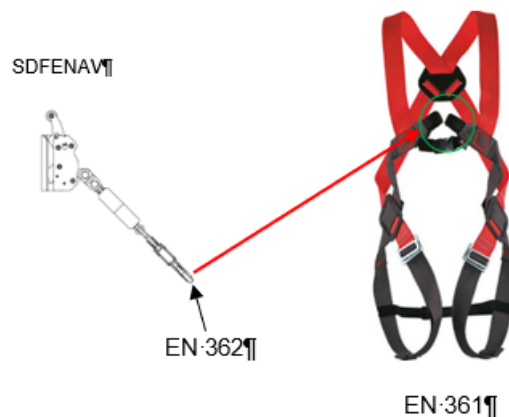

If the harness becomes loose during ascent or descent, it should be correctly adjusted again from a secured position.

## 2.3 SDFENAV installation

A feature system is included in the SDFENAV guided type fall arrester protect against incorrect orientation, then a specific marking on SDFENAV completes it by indicating the direction of use for the ascent.

To install the SDFENAV on the anchor line, follow the instructions below. Once the lever is closed, it prevents the device from escaping from the anchor line. Before use, always check the correct orientation of the device on the anchor line by carrying out a manual locking test. Once installed, the device is free to slide along the anchor line cable without any intervention from the user. Any sudden downward movement (falling or descending too fast) causes the device to lock onto the cable while retaining the user.

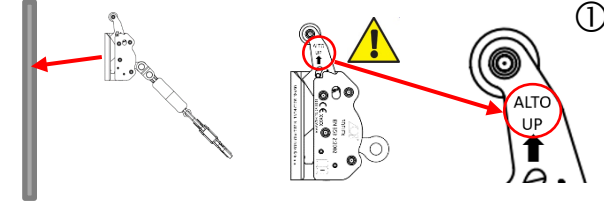
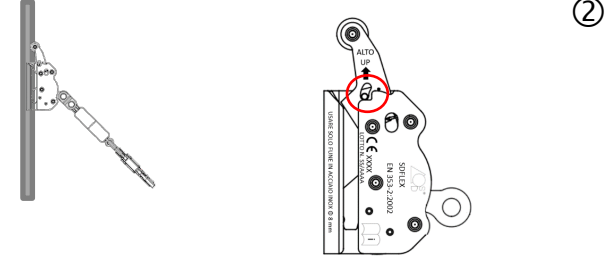
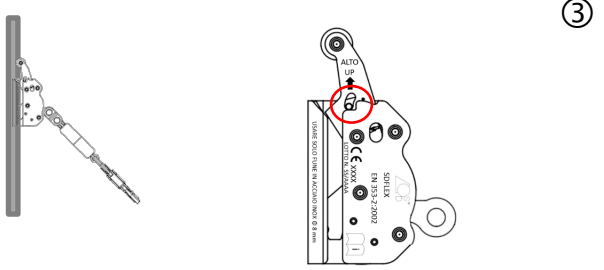
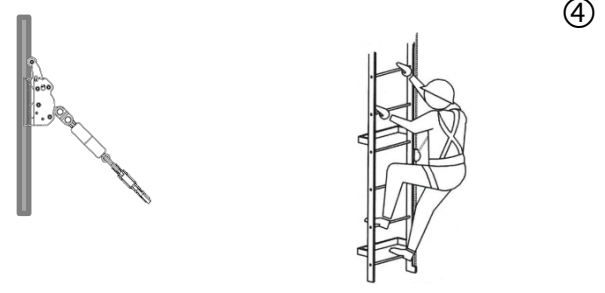
 <p>1</p> <p>Arrange the SDFENAV according to the direction of use.</p>	 <p>2</p> <p>Open the lever to insert the SDFENAV on the vertical line rope. Then insert the 8 mm diameter cable into the trolley flange.</p>
 <p>3</p> <p>Close the lever previously open.</p>	 <p>4</p> <p>The SDFENAV is thus correctly installed on the vertical anchor line and after the clamping test, the operator can anchor and climb the ladder safely.</p>

For the 3 first meter, the user cannot be protected against fall from height and can hit the ground. It is a matter of taking extra precautions when climbing or descending this part.

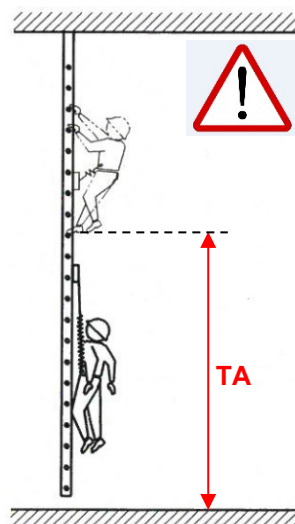

## 2.4 Prohibited uses

Engaging the guided type fall arrester's release function or handling the guided type fall arrester during ascent or descent could hinder the safe operation of the braking mechanism and should be done only from a safe position where there is no risk of a fall.

It is forbidden to connect or disconnect from the rigid anchor line; it shall be done from a safe place or by using a separate personal fall protection system.

It is forbidden to use the SDFENAV mobile fall arrester for work positioning and that if work positioning is required, a separate system shall be used.

It is strictly forbidden to modify the length of the connecting element on the SDFENAV mobile fall arrester by adding or subtracting.

It is forbidden to use the equipment in rescue situations.

It is forbidden to install equipment in an aggressive or highly corrosive atmosphere (for example, above a swimming pool) due to the risk of corrosion cracking under invisible stress, unless specific control measures are implemented, or compatibility is established.

It is forbidden to use the equipment in a high humid condition when raining and in case of lightning.

The SDFLEX produced by Sicur Delta can be affected by atmospheric discharges also based on the material constituting each element. On the basis of this indication it will be down to the customer, or the installer or the owner or the person responsible for the management of the fall arrest system (owner of the property, administrator, H&SO, employer, etc.) to verify, based on the relevant regulations in force, whether the building (place of installation) is protected with the installed system, or to ensure that measures and systems suitable to make it protected are adopted.

The installation of the device must be carried out at a suitable distance from live bare cables (in compliance with current regulations), electrical systems and have no connections either with these or with antennas or other systems that can become live and act as a conductor, as the components of the SDFLEX personal protective equipment could accidentally become live: a careful risk assessment must be arranged before installation.

### 3 MARKING

#### 3.1 Marking

The marking on the guided type fall arrest device and on the rigid anchor line complies with EN 365:2005 as required by EN 353-1:2014+A1:2017.

Below is a diagram showing the content and meaning of the marking.

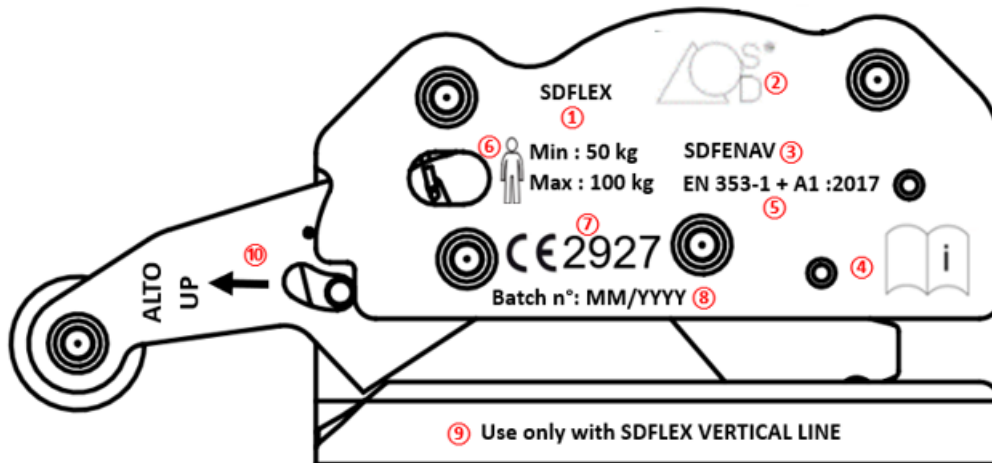

Marking of the SDFENAV fall arrester

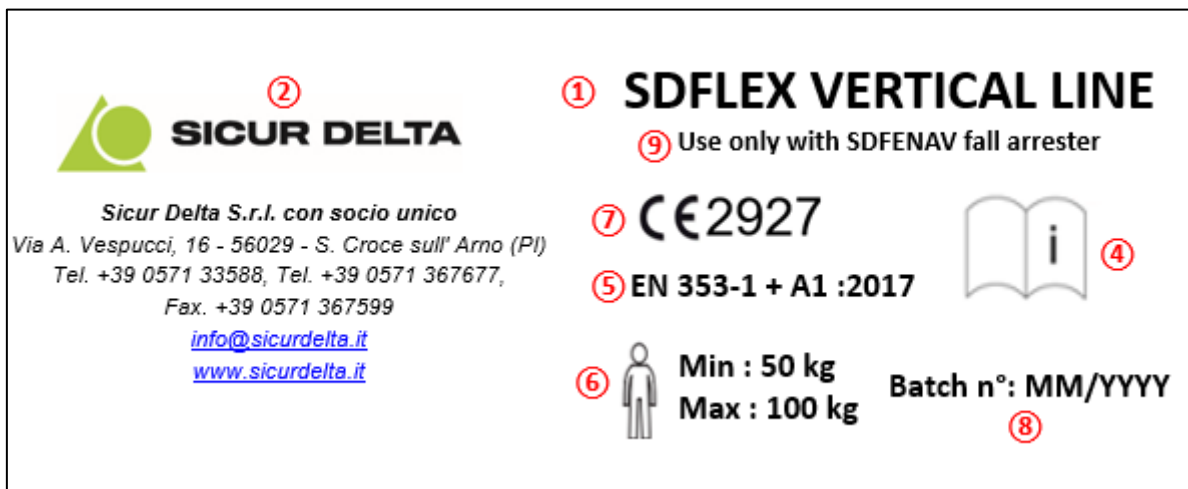

Marking near the SDFLEX VERTICAL LINE

- ① model of the PPE
- ② manufacturer SICUR DELTA
- ③ reference of the fall arrester
- ④ Read the instructions for use
- ⑤ compliant standard
- ⑥ use by a user of a weight between 50 kg (excluding equipment) and 100 kg (including equipment)
- ⑦ CE marking follow with identification number of the notified body in charge of the production control
- ⑧ batch month / year
- ⑨ indication using only with rigid anchor line or fall arrester
- ⑩ Good direction of use

The other components only report the manufacturer's lot number and logo as indicated below. The lot number is essential to determine the service life of the device.



The lot numbers of the elements constituting the device may differ from each other. As specified in paragraph 5.3, the lot number to refer to for the service life of the product is the one with a date prior to the others.

## 4 INSTALLATION INSTRUCTIONS

The installation of the SDFLEX personal protective equipment involves two assembly phases:

- 1) Installation of the Flexible Anchor Line
- 2) Installation of the TROLLEY on the anchor line (see chapter 2.3)

### 4.1 Installation recommendations

It is necessary to ensure installation methods that guarantee health and safety conditions to installers, in accordance with current regulations on health and safety in the workplace. Installers are also required to respect them.

Sicur Delta S.r.l. recommends that the installation of the personal protective equipment be carried out by personnel with adequate skills and training. The installer must be an expert adequately trained and instructed for this task, with knowledge of both the installation and the methods of inspection after installation to be carried out on the devices covered by the manual.

Sicur Delta prepares and trains installers and inspection/maintenance technicians of personal protective equipment. To have the list of skilled personnel trained and instructed and therefore suitable to install SDFLEX range devices, contact the manufacturer Sicur Delta S.r.l. directly.

### 4.2 Assembly and installation methods

Before proceeding with the installation, it is necessary to check that the ladder is correctly fixed to the load-bearing structure.

Should any issues be found that do not allow the installation to be correctly performed, immediately interrupt the installation, and contact the designer, safety manager or Sicur Delta.

Once the suitability of the support structure (ladder) on which the vertical line will be fixed has been verified, it is necessary to ensure that the devices, in every component and element, do not present damage or defects and that they are intact and correctly pre-assembled where stated.

The elements of the Sicur Delta SDFLEX of personal protective equipment must be assembled according to the installation and assembly instructions in this manual and must not be replaced with elements from a different manufacturer, or with other Sicur Delta elements other than those indicated. The use of elements other than those indicated, or failure to assemble some of the components described, involves the configuration of hybrid systems not authorised by Sicur Delta and is potentially dangerous.

Below is an outline of the procedure to be followed for the installation:

Below is an outline of the procedure to be followed for the installation:

#### 4.2.1 Installation inferior element SDFEINF

	<p>Place the bottom bracket element SDFEINF at the bottom of the ladder (second to last and third last step)</p>		
	<p>FIXING WITH STRAIGHT BRACKET SLSDFSTDR</p>	<p>Secure the SDFEINF lower bracket element to the rungs of the ladder using the brackets provided with a straight fixing bracket (for "Universal" ladder) or omega bracket on the rung (for mounting on a ladder provided by Sicur Delta).</p>	
	<p>OMEGA SLSDFSTOM FIXING</p>		
<p>FIXING WITH STRAIGHT BRACKET SLSDFSTDR</p>	<p>OMEGA SLSDFSTOM FIXING</p>	<p>The fixing bracket-step union is realized with the supplied fixing screws. For the universal straight bracket M10x60 hex head screw + M10 self-locking nut + M10 washer. For the omega bracket M10x25 hex head screw + M10 self-locking nut + M10 washer. All fixings are made of stainless steel</p>	
			<p>Tighten the nut with a TORQUE WRENCH Tightening torque 30Nm</p>

#### 4.2.2 8 mm diameter SDFCAVO cable assembly with SDFTEND tensioner

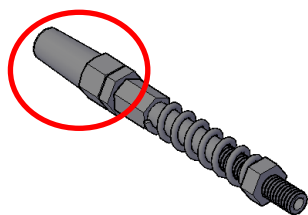

Unscrew and remove the conical part of the tensioner, taking care not to lose the components inside.

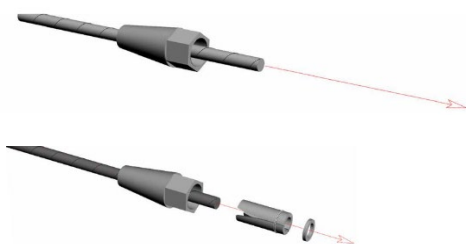

Proceed with inserting the cable into the conical end.

Then assemble the other elements of the cable clamp, as indicated in the sequence of images to the side.



Once crossed the internal components of the cable clamp, the cable must be brought into contact with the cavity inside the male thread of the component with ring. In order for the cable to come into contact with the cavity, it must escape from the internal elements of the cable clamp by 10 mm, as shown in the image in detail.



Screw the conical part to the tensioner and lock the cable clamp through the locking nut, turning it counterclockwise and bringing it in contact with the semi-conical component of the tensioner.



The cable correctly installed must be as from image to side.

### 4.2.3 Assembly of SDFTEND tensioner to SDFEINF bottom bracket element

Insert the tensioner in the hole on the vertical side of the bracket.

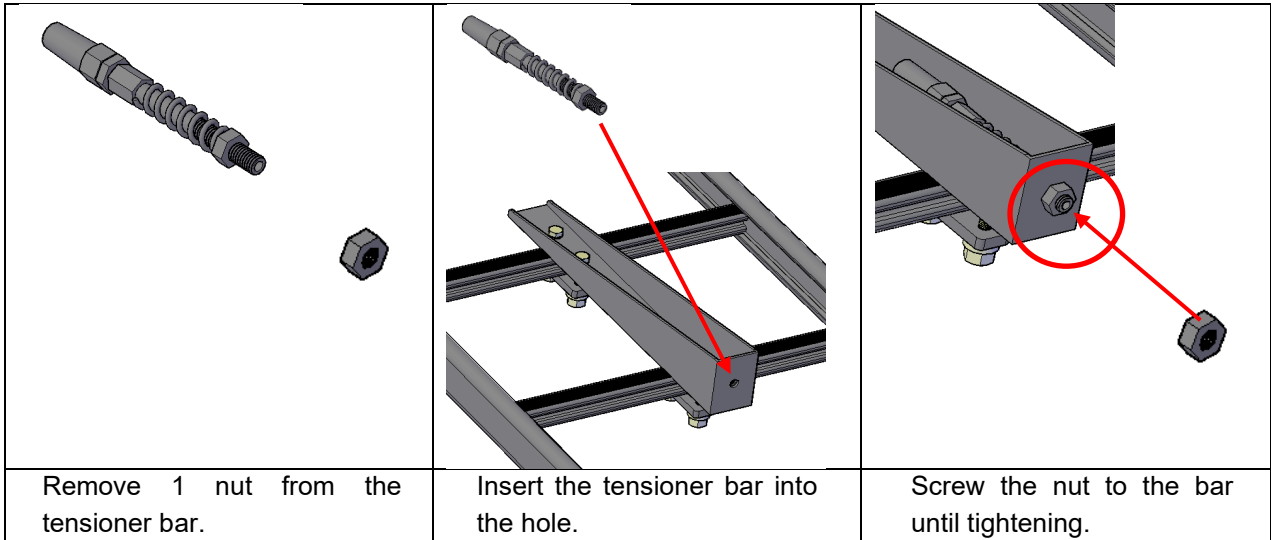

### 4.2.4 SDFESUP top anchor installation

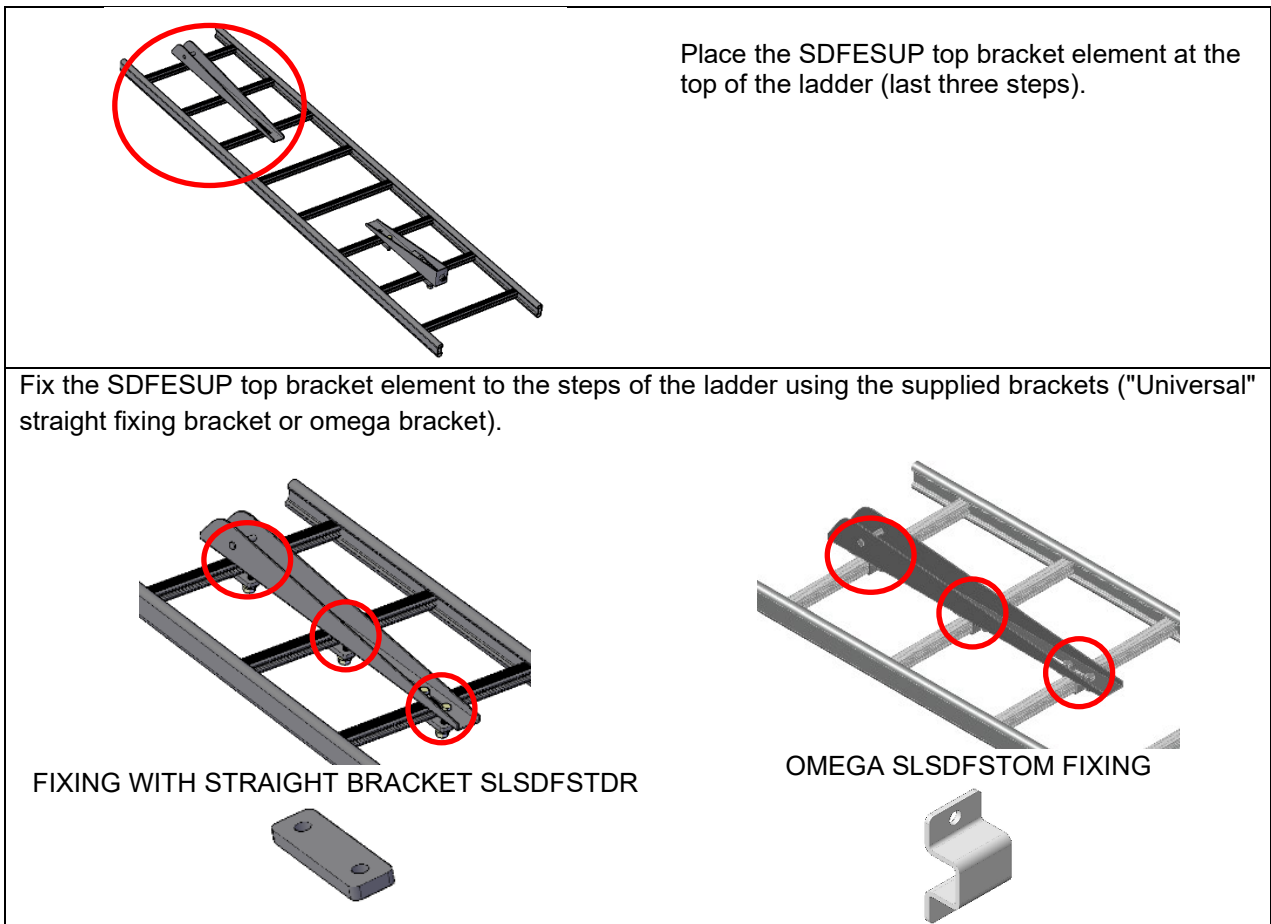

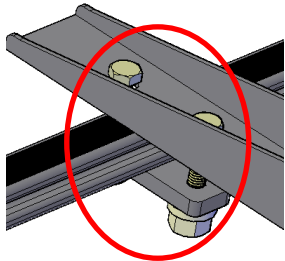

**FIXING WITH STRAIGHT BRACKET SLSDFSTDR**

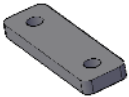

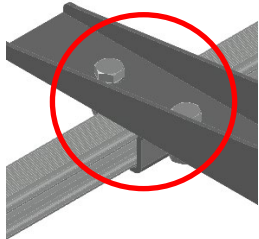

**OMEGA SLSDFSTOM FIXING**

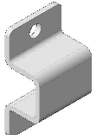

The fixing bracket-step union is realized with the supplied fixing screws.

For the universal straight bracket M10x60 hex head screw + M10 self-locking nut + M10 washer.

For the omega bracket M10x25 hex head screw + M10 self-locking nut + M10 washer.

All fixings are made of stainless steel



Tighten the nut with a TORQUE WRENCH  
Tightening torque 30Nm

#### 4.2.5 SDFSERR cable clamp kit assembly.



Insert the cable into the device from the unfinished part for about 20 cm.



Flip it over and reinsert the end towards the side with the two grains.



Before reintroducing the cable in the black block insert the redance in the loop that has been created.





Pull the cable and adhere the redance well. Tighten the grains to 16 Nm.

II The properly installed cable clamp will have to result as shown below.

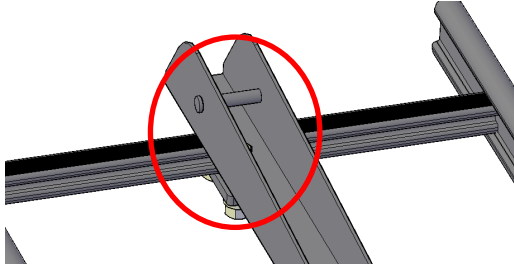

Proceed by inserting the cable just wrapped in the upper anchor.

	<p>On the upper anchor there is a 12 mm diameter retainer that serves to fix the vertical line cable.</p>
	<p>The latch is formed by a pivot (1) equipped with a pin (2), that is an elastic safety ring in steel for the closure..</p> <ul style="list-style-type: none"><li>- Remove the pivot on the pin and the pin itself.</li><li>- Install the crimped end of the cable on the top anchor bracket, aligning the two components.</li><li>- Close the joint with pin and closing pin.</li></ul>

#### 4.2.6 SDFESB2 upper anchor installation

Place the upper bracket element SDFESB2 at the top of the ladder considering that the first 4 steps will be necessary for fixing

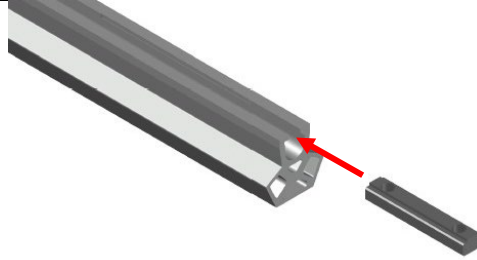
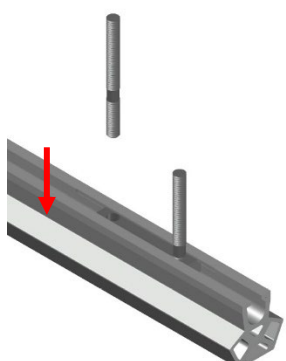
	<p>Take the 4 connectors supplied, necessary for fixing to the steps, and insert them in the appropriate housing of the landing bracket SDFESB2 as shown in the figure.</p>
	<p>Use for each n connector 2 studs 10x101 supplied, as shown in the figure.</p>

Fix the upper bracket element SDFESB2 to the 4 upper steps of the ladder as shown in the following figures. Use the supplied bracket, which can be:

- the universal straight mounting bracket (for steps up to 50x50mm)
- the omega bracket (for the assembly on a 30x30mm square step, scale size provided by Sicur Delta).

Tighten each screw with self-locking nut M10 and washer M10 supplied

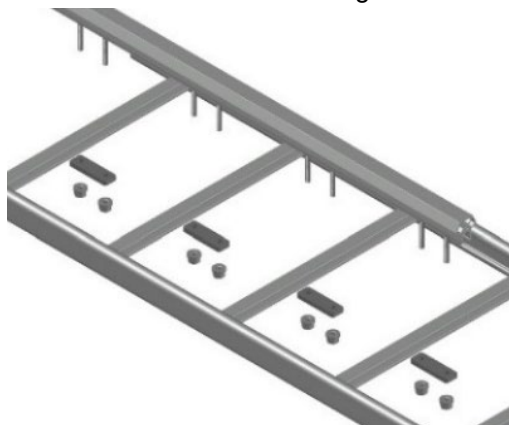

UNIVERSAL BRACKET FIXING

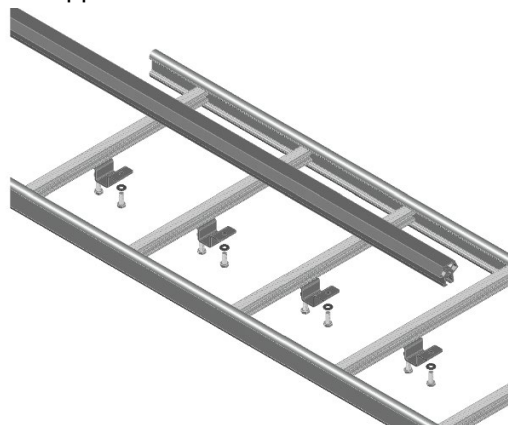

OMEGA FIXING

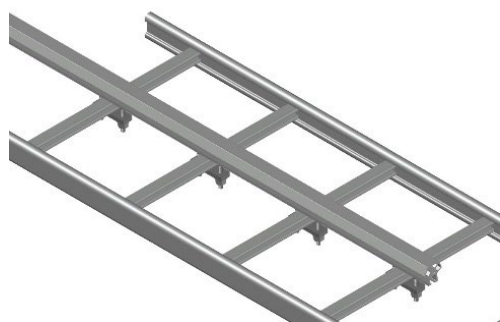

The properly assembled SDFESB2 upper landing shall be as shown on the side.

#### 4.2.7 SDFSERP cable clamp component assembly.

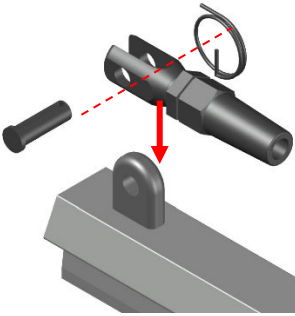
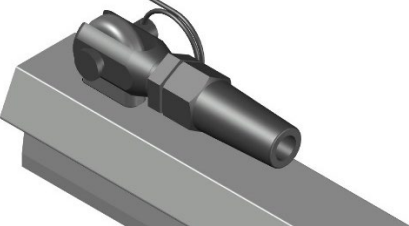
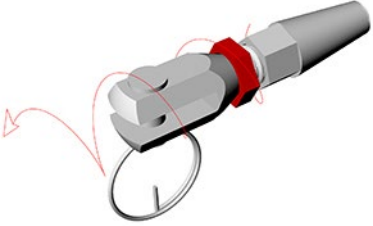
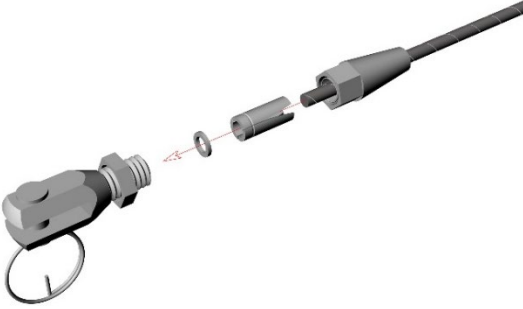
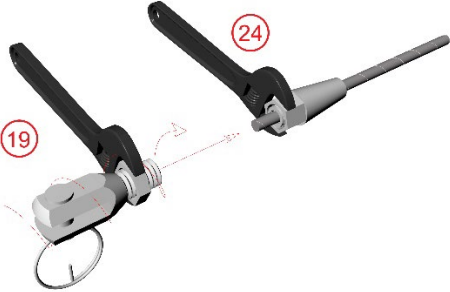
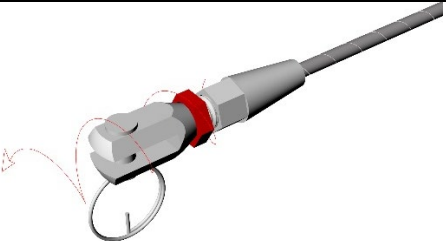
	<p>At the top of the landing bracket SDFESB2 is necessary to assemble the cable clamping device . Insert the fork of the device in the special pin already assembled on the landing bracket and join the two components by inserting the appropriate pin and the cotter pin in the hole .</p>
	<p>The suitably assembled cable clamp should be as from image to side .</p>
	<p>Open the cable clamp, rotating the semiconical component counterclockwise, and remove the components inside. Be careful not to lose or damage the internal components of the cable clamp .</p>
	<p>Proceed with the passage of the cable inside the components as from figure to side</p>
	<p>Tighten the cable by closing the cable clamp: hold the half-conical part with the cable and the internal elements of the terminal locked, with the key measuring 24, and rotate the opposite part of the clamping terminal (end part with ring), where the cable is keyed with 19 key, until you get to complete tightening.</p>
	<p>Lock the cable clamp through the locking nut, turning it counterclockwise and bringing it to a stop with the semi-conical component of the tensioner</p>

### 4.3 SDFEINT intermediate element installation

If the anchor line exceeds 10.00 m, it is necessary to install the intermediate element that serves to prevent the cable from bending too much over large lengths.

The element is installed on a single step at about half of the section (eg: staircase from 16.00 m, intermediate element positioned at 8.00 m).

INTERMEDIATE FIXING WITH OMEGA BRACKET

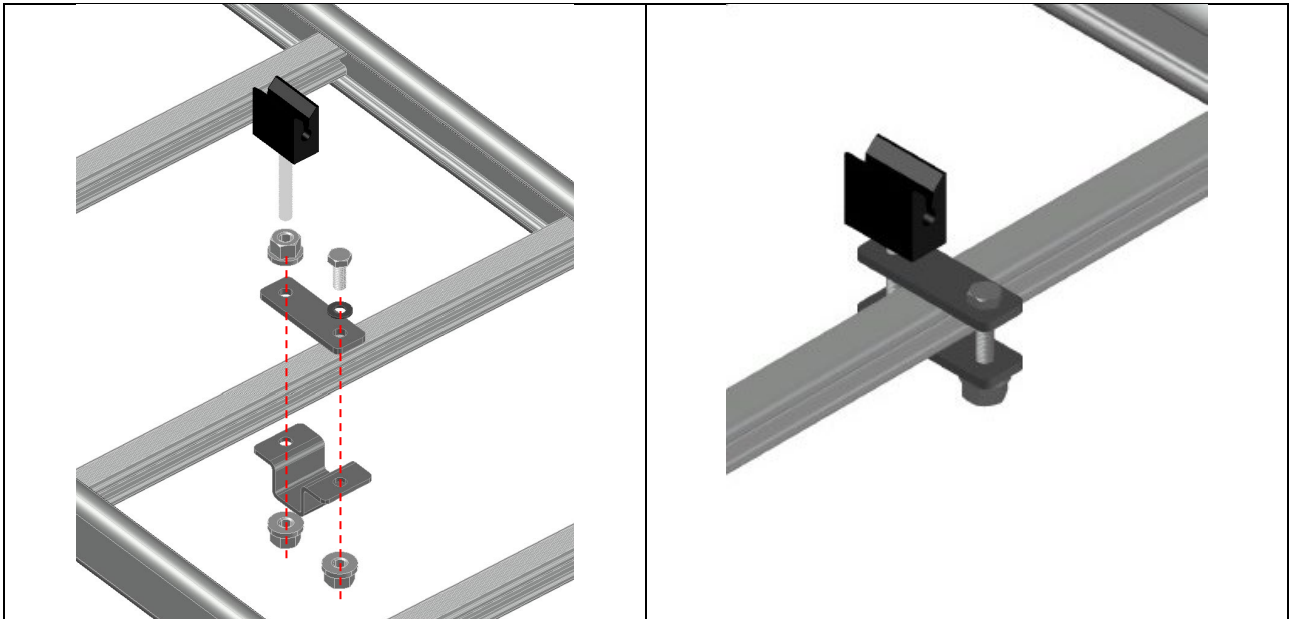

INTERMEDIATE ASSEMBLY WITH UNIVERSAL BRACKET

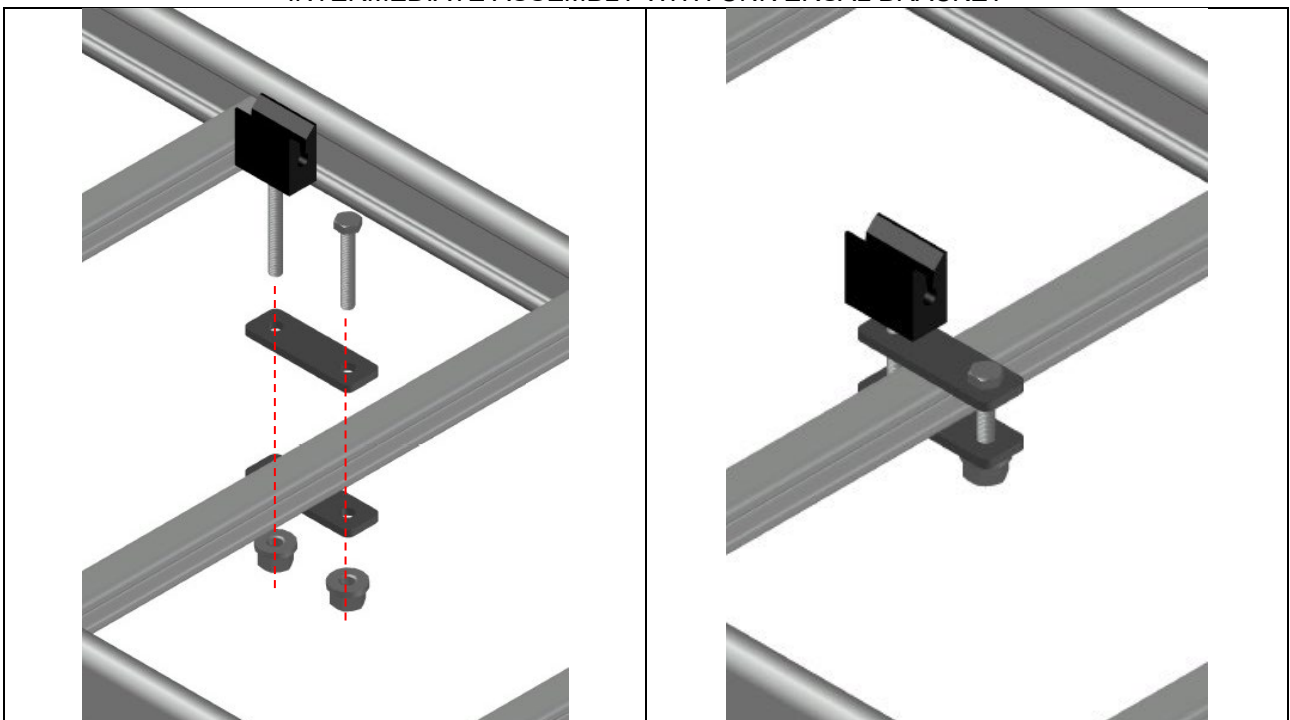

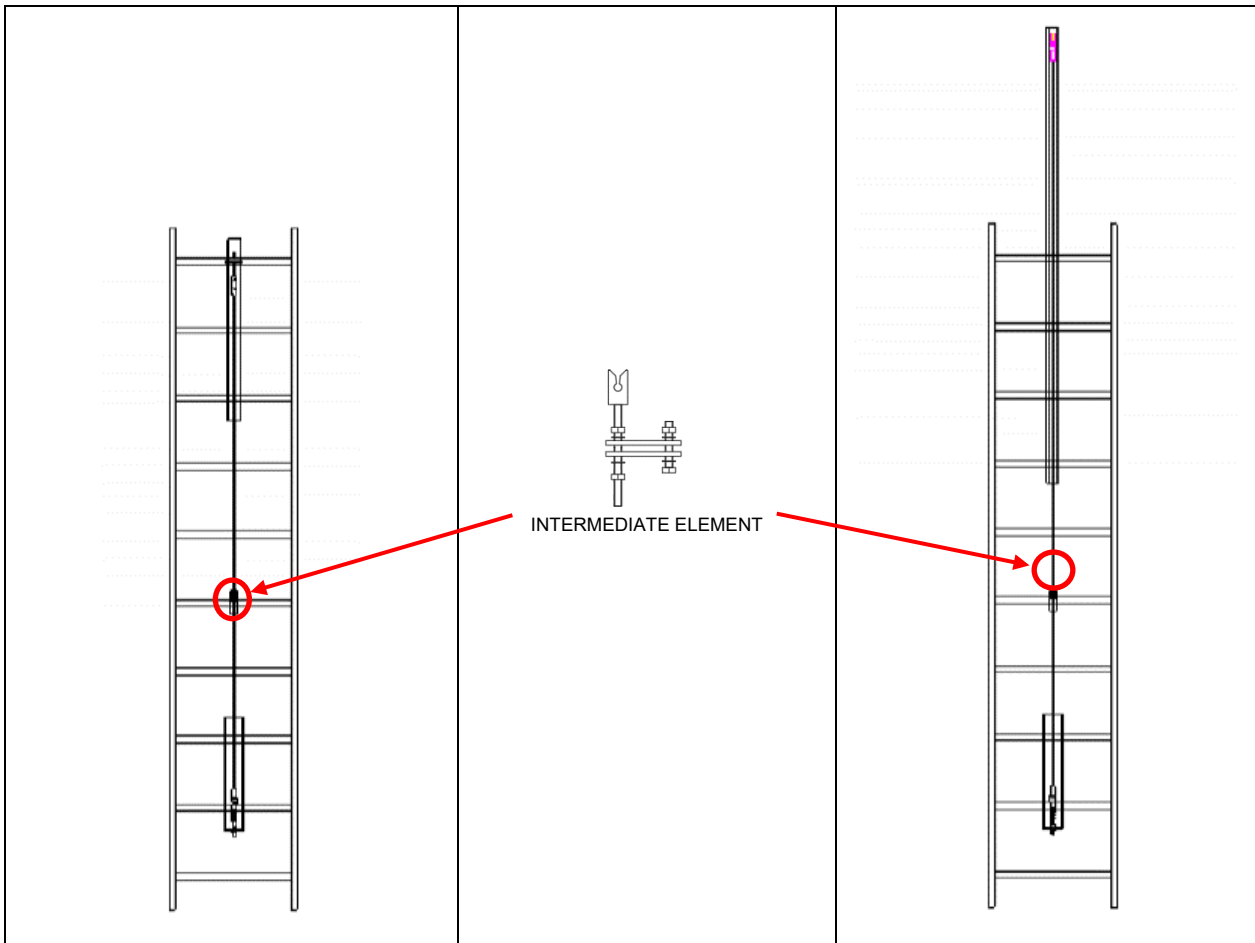

## 5 ROUTINE INSPECTION, MAINTENANCE and SERVICE LIFE

For the installation, also for the operations described in this chapter, it is recommended that they are carried out by personnel with adequate skills and training. The inspection/maintenance technician must be a person adequately trained and instructed for this task, with knowledge of both the installation and the methods of inspection and maintenance operations to be carried out on the devices covered by the manual. It is advisable to contact the manufacturer Sicur Delta srl directly for the contact details of skilled professionals.

Sicur Delta instructs people to gain the required skills or to update their skills during the routine inspection of PPE or other equipment through accredited training.

Repairs of any kind are not allowed on the SDFLEX personal protective equipment.

After falls or damage of the device, repairs are not allowed since the product may suffer permanent deformations not visible to the naked eye. In such cases, the device must be put out of service, then removed and subsequently decommissioned.

In addition to the actions allowed in routine inspections, the replacement of elements or components with original parts provided by the manufacturer Sicur Delta may be evaluated subject to the manufacturer's authorisation.



**REPAIRS ARE NOT ALLOWED UNDER ANY CIRCUMSTANCES.**

### 5.1 Routine inspection



ROUTINE INSPECTION OPERATIONS ON AN **ANNUAL BASIS** ARE NECESSARY TO ENSURE THE PROPER FUNCTIONING OF THE PERSONAL PROTECTIVE EQUIPMENT IN ORDER TO ENSURE USER SAFETY.

User safety depends on the continuous efficiency and durability of the equipment. In addition to the normal visual inspection carried out before, during and after each use, this product must be examined by an expert every **12 months**, starting from the date of the first use of the product. The recording of this date and the subsequent checks must be carried out on the product life sheet: keep the documentation for the check and for reference throughout the life of the product.

Particular environmental and use conditions, such as frequent use of the personal protective equipment or exposure to the environment that can accelerate the corrosive process of the material, are aspects that call for more frequent inspections. The designer (s), installer or future inspection/maintenance personnel may reduce inspection times based on their own assessments of the system.

Personal protective equipment that has not been inspected within the indicated timeframe must be decommissioned.

Routine inspection consists of a thorough examination of the personal protective equipment to check for damage or defects, such as deformation or wear. The first part of the routine inspection coincides with the inspection before use, which is to be understood as a direct check of the good condition of the installed device through a recorded and visual check.

**5.1.1 Check the documentation accompanying the fall protection device, carrying out a check on compliance with the time intervals for inspection operations, which if not respected lead to the decommissioning of the device.**

If documentary deficiencies are detected, put the personal protective equipment out of service.

**5.1.2 Visual inspection of the device and each of its components to ensure good general condition, if there are signs of corrosion, deterioration, or damage, such as dissipation/deformation of some element or displacements of the anchor point not allowed. These checks include:**

- Checking marking legibility.
- Check the good condition of the device through a visual inspection of the lower and upper anchorage, upper anchorage with outreach section, intermediate, cable, tensioner, cable clamp, connection screw brackets, bolts (check the correct tightening).
- Check for cracks or crushes on the EN 353-1:2014+A1:2017 trolley flange or lever.
- Check that there is no excessive wear in the connector housing on the energy absorber.
- Check the correct locking of the lever and, if necessary, lubricate the mechanism.
- Check that there is no excessive wear on the part of the trolley that slides on the rope. These could wear the cable and damage it.
- Check that there is no excessive clearance between the locking pin of the energy absorber damper and the trolley.
- Check that the energy absorber has not come into operation.
- Check the presence of all lower and upper anchorage and/or upper anchorage with outreach section.

If faults, defects or damage to the product are detected, it must be immediately put out of service.

**5.1.3 Functional and/or instrumental checks on the device (s).**

- Clean to remove dirt, corrosive agents, any deposited material or other unauthorised adhesives, labels or writings: do not use chemicals that may damage the material such as acids or similar. For cleaning textile and plastic parts, wash only with fresh water and neutral soap (maximum temperature 30°) and allow to dry in a natural way, away from direct sources of heat. For metal parts wash with fresh water and dry.
- Check and adjust tightening torques of bolted joints (if present).
- Check the fixings for looseness or detachment.

Please refer to the chapter on the characteristics of the personal protective equipment and its installation, which must be carefully studied before carrying out an inspection/maintenance, where images and details are shown on the components and elements of the fundamental devices to carry out the above described.

If faults are detected on the necessary controls or actions, even if unsure, the device must be immediately decommissioned.

If the item is suitable for documentary verification, visual inspection and the latter functional and instrumental checks, (therefore any necessary corrective actions have been implemented) the routine inspection and its positive outcome must be reported with the assumption of responsibility by the inspection/maintenance technician in Appendix A of this manual on THE EQUIPMENT CHECK LOG SHEET in which the entire record of the operations carried out on the device during its lifespan is reported.

The check log sheet must be kept by the customer. The check log sheet is an integral part of the personal protective equipment.

## 5.2 Maintenance

Since maintenance is the set of actions necessary for the correct and safe operation of the personal protective equipment, the necessary maintenance operations have been indicated among those reported in the routine inspection, therefore maintenance coincides with routine inspection, in terms of actions, timings and personnel. In addition to the actions allowed in routine inspections, the replacement of elements or components with original parts provided by the manufacturer Sicur Delta may be evaluated subject to the manufacturer's authorisation.

Please note that repairs are not allowed under any circumstances.

## 5.3 Service life

The SDFLEX has a life of **30 years** in the absence of causes that require its decommissioning, and provided that all the planned inspections and any necessary maintenance are carried out, with recording of their results in **THE EQUIPMENT CHECK LOG SHEET**.

The 30-year service life starts from the manufacture of the device, in fact the batch number of the product shows its week and year: for example, a device with batch number 36/2023 can have a maximum life up to week no.36 (inclusive) of the year 2053.

When the personal protective equipment is composed of several elements with different batch numbers, the oldest of these must be taken as a reference for the purpose of calculating the service life (for example between 30/2020, 35/2021 and 15/2023 the reference date is 30/2020). Since during inspections it is possible that a component of the product may be replaced, at its first installation the maximum service life date must be indicated, which cannot be further postponed.

The person responsible for the management of the personal protective equipment (property owner, administrator, H&SO, employer, etc.) is responsible for:

- ensuring routine inspection is carried out (also including maintenance operations as explained in the chapter);
- **taking care of** decommissioning ensuring the device is NOT USED if:
  - Questions arise about possible safe and correct operation, therefore about the suitability of the product.
  - During the inspection before use, the use itself or the routine inspection highlighted anomalies or issues.
  - The device arrested a fall or damage occurred.
  - The service life of the device/system has elapsed.
- having the device decommissioned once it has been put out of service.

## 6 PACKAGING, STORAGE, TRANSPORTATION

All personal protective equipment is provided by Sicur Delta in its own packaging, so as to prevent any loss or exchange of elements or components of the product, in addition, the packaging prevents the formation of dust, dirt and accidental damage during storage. It is important to check that the packaging is not damaged, otherwise it is necessary to check with caution the presence of any damage to the item itself.

The SDFLEX must be stored inside the box/packaging both during storage and transport, making sure to prevent damage, it is therefore advisable to provide additional external packaging.

To store the product the ideal place must be dry, ventilated and not exposed to fumes, with low humidity and not saline, away from exposures that facilitate corrosion, from heat sources, sharp objects or that can crush it and any other possible source of damage or deterioration: shocks, non-compliant uses, contact with chemicals and high temperatures can reduce the life of the product or damage it.

This product must be kept at a temperature below 80° so as not to compromise its performance and safety.

The device must be discarded in case of exposure to temperatures above 80°C and if it has come into contact with chemical reagents, solvents or fuels, which could alter the characteristics of the product.

In addition, once purchased by the end user, this must be stored on the transport vehicle until installation is required in order to avoid bumps, shocks and vibrations.

## 7 WARRANTY

Compliance with product technical standards, subject to tests carried out in the field of testing at an accredited laboratory, is issued with the EU declaration of conformity.

Regulatory compliance, both production and product, offers A GUARANTEE OF TRUTHFULNESS, synonymous with the functional goodness of the devices.

The duration over time of the anchoring devices, not being able to predict the place of installation, the frequency of use and multiple conditions around the installed and used product, is subject to interventions that maintain the good state of efficiency and safety. As specified in the chapter on inspections and maintenance, the maximum service life of the device is 30 years in the absence of causes that require its decommissioning, and provided that all the scheduled routine inspections and any necessary maintenance are carried out, with recording of their results in **THE EQUIPMENT CHECK LOG SHEET**.

Upon receipt of the material (personal protective equipment SDFLEX) the recipient has the obligation to ensure that the delivery fully corresponds to the order for quantity of components. The acceptance of the material is equivalent to confirming said correspondence.

This product has a warranty of 30 years from the date of purchase, against any defect of the material or manufacture. The following are not covered by the warranty: normal wear, modifications or touch-ups, poor conservation, corrosion, damage due to accidents and negligence, uses for which this product is not intended.

## 8 SDFLEX VERTICAL LINE COMPONENTS











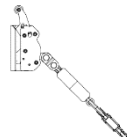
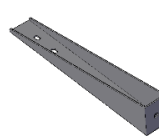





COMPONENTS				
1. Rope grab – SDFANEV	1.			
2. LOWER ANCHORING a. SDFEINF Lower element bracket b. SDFTEND lower element tensioner c. SLSDFSTDR Straight fixing bracket d. Omega bracket for rung fixing SLSDFSTOM	2.a	2.b	2.c	2.d
				
3. UPPER ANCHORAGE a. SDFESUPU Upper bracket element b. Cable Clamp SDFSERR c. SLSDFSTDR Straight fixing bracket d. Omega bracket for rung fixing SLSDFSTOM	3.a	3.b	3.c	3.d
				
4. UPPER ANCHORAGE WITH OUTREACH SECTION a. Element 2.00 m SDFESB2 outreach section b. Track-Ladder fixing CONNECTOR + SCREW + SELF-LOCKING NUT + M10 WASHER + BRACKET c. Vertical Line Upper Anchor d. Cable Clamp SDFSERP	4.a	4.b	4.c	4.d
				
5. INTERMEDIATE ELEMENT a. SDFEINT intermediate element b. SLSDFSTDR Straight fixing bracket c. Omega bracket for rung fixing SLSDFSTOM	5	5.b	5.c	
				
6. CABLE Cable $\Phi$ 8 mm (AISI 316 7X7)	6.			
				
ACCESSORIES				
7. FIXING SCREWS	7.			
				

Table 2 – Components and accessories vertical line SDFLEX

# **DESCRIPTIONS AND TECHNICAL DATA SHEET**

## ➤ COMPONENTS

### 8.1 Rope grab – SDFANEV

<p>EN 353-1:2014 + A1:2017 certified sliding trolley for 8 mm diameter stainless steel cable (7x7 AISI 316) SDFLEX.</p> <p>The trolley featured an automatic locking system that allows ascending and descending without having to perform manual manoeuvres. If the worker loses grip and slips, the device stops immediately breaking the fall.</p> <p>An energy absorber and an EN 362 connector are attached to the trolley allowing attachment to the sternal anchorage point of the user's EN 361 harness. All components are made of stainless steel to ensure durability. The energy absorber is made of textile material.</p>				<p>1.</p> 
CODE	DESCRIPTION	DIMENSIONS [mm]	WEIGHT [kg]	
SDFENAV	Rope grab – SDFANEV	270x140x22mm	1.85	

Table 3 – Description Rope grab -SDFANEV.



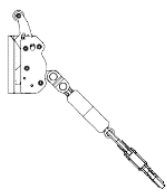

TROLLEY COMPONENTS	NOMENCLATURE
 <p>1 TROLLEY ITEM 2 DAMPER 3 CONNECTOR EN 362</p>	 <p>1 FLANGE 2 LEVER 3 DAMPER + CONNECTOR COUPLING</p>

Table 3.1 – Technical data sheets Rope grab - SD trolley

## 8.2 Lower anchorage

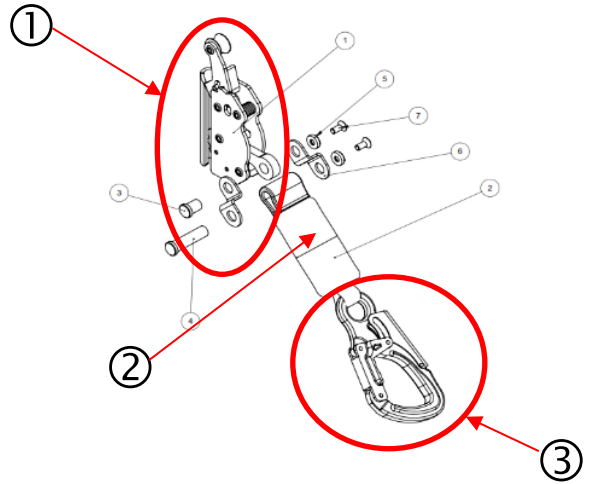
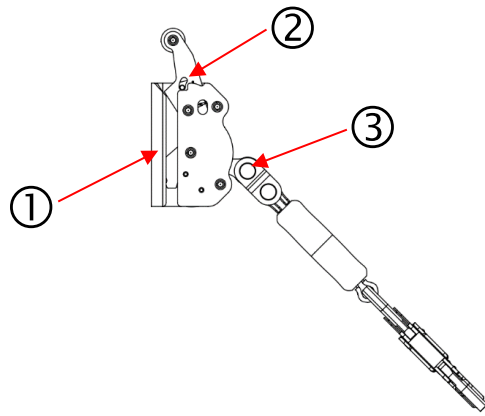
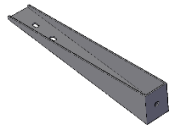
<p>Lower fixing element, in AISI 304 stainless steel, for a rigid vertical anchoring line. The element consists of:</p> <p>1) A bracket (2.a) flat base 60x500 mm thick. 3 mm with four slotted holes (two of them 11x40 mm and the other two 10x20 mm) for fixing to the ladder, long triangular vertical side 80x500 mm thick. 3 mm, lower short side 80x60 thick. 3 mm with a central hole <math>\Phi</math> 12.5 for attaching the tensioner.</p> <p>2) A tensioner to give the right tension to the vertical line cable. The tensioner is secured to the bracket by means of the M14 nut and lock nut present in the threaded end part.</p> <p>3) Fixing brackets on ladder rung. The models of brackets available are:</p> <ul style="list-style-type: none"> <li>• <b>Straight bracket</b> (for “universal” ladder) 2.c</li> <li>• <b>Omega bracket</b> (for ladders provided by Sicur Delta) 2.d</li> </ul>				 <p>2.a</p>  <p>2.b</p>  <p>2.c</p>  <p>2.d</p> <p>Lower anchorage</p> 
CODE	DESCRIPTION	DIMENSIONS [mm]	WEIGHT [kg]	
SDFEINF	Lower bracket ladder vertical line	60x500x3 H=80	2.30	
SDFTEND	Vertical line tensioner	L=214	0.40	
SLSDFSTDR	Straight bracket for rung fixing	31x97x10	0.20	
SLSDFSTOM	Omega bracket for rung fixing	50X89X4 H=33	0.20	

**Table 4 – Lower Anchorage Description**

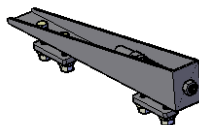
## LOWER BRACKET

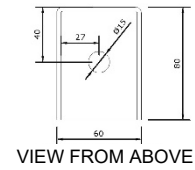
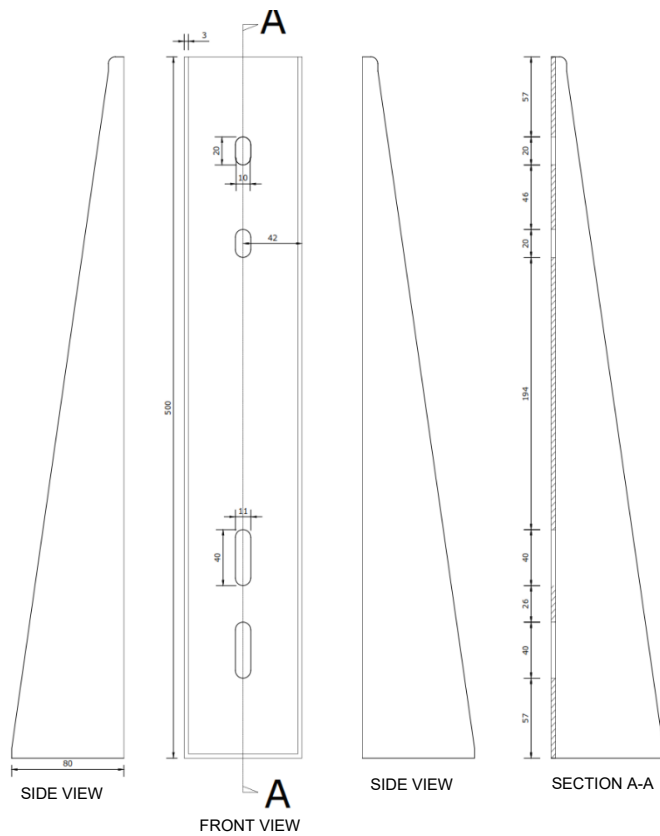

### TENSIONER

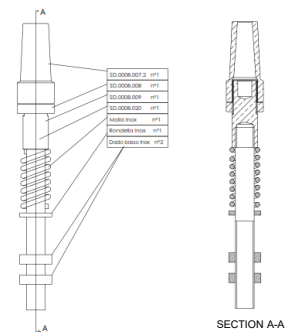

STRAIGHT FIXING BRACKET	OMEGA FIXING BRACKET
-------------------------	----------------------

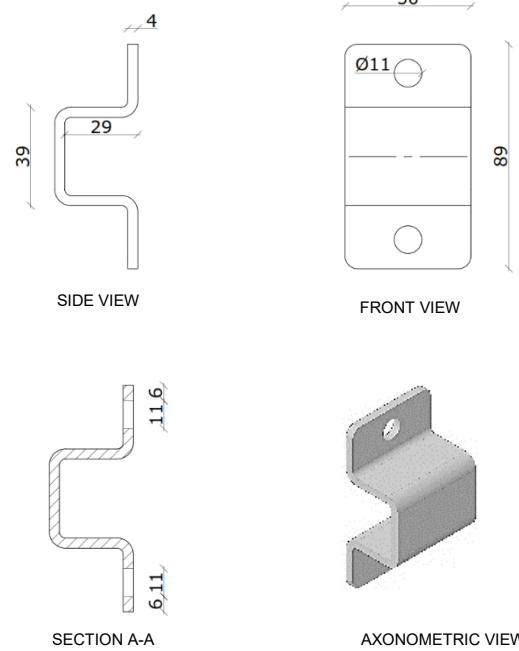
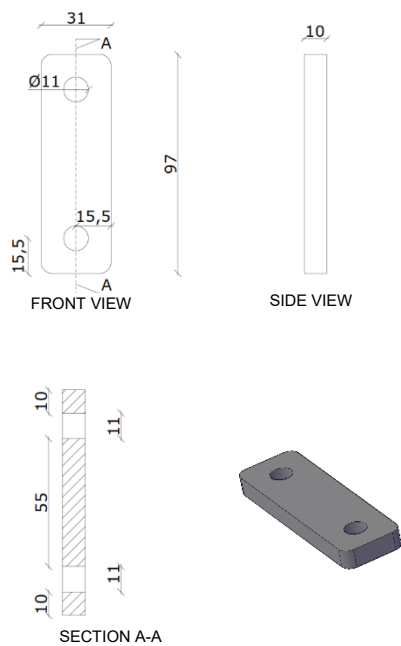

**Table 4.1 – Lower Anchorage Technical Data Sheets**

### 8.3 Upper anchorages

Upper fixing element, in AISI 304 stainless steel, for rigid vertical anchoring line.

The element consists of:

1) A bracket (3.a) flat base 60x800 mm thick. 3mm with 5 slotted holes (two of them 11x20 mm, other two 11x40 mm and the last one 11x126 mm) for fixing to the ladder, vertical triangular long sides 80x800 mm thick. 3 mm. In the upper part of the triangular side there is a  $\Phi$  12.5 hole on both sides into which the AISI 316 stainless steel plug must be inserted. The cable of the vertical anchor line will be attached to the latter through a thimble.

2) A 6082 aluminium cable clamp kit complete with thimble and two 8x10 grubs for adjusting the rope to the size of the ladder.

3) Fixing brackets on ladder rung.

The models of brackets available are:

- **Straight bracket** (for “universal” ladder) 3.c
- **Omega bracket** (for ladders provided by Sicur Delta) 3.d

CODE	DESCRIPTION	DIMENSIONS [mm]	WEIGHT [kg]
SDFESUP	Upper bracket vertical ladder line	60x500x3 H=80	3.70
SDFSERR	Cable Clamp for Vertical Line	35x80x23.2	0.30
SLSDFSTDR	Straight bracket for rung fixing	31x97x10	0.20
SLSDFSTOM	Omega bracket for rung fixing	50X89X4 H=33	0.20



3.a



3.b



3.c

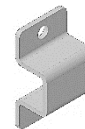

3.d

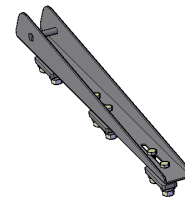

Upper anchor

*Table 5 – Upper Anchorage Description*

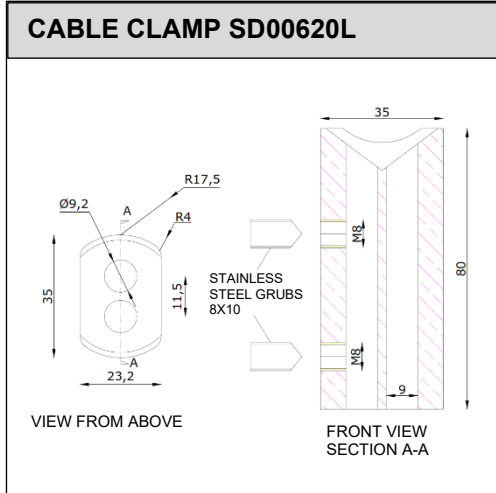
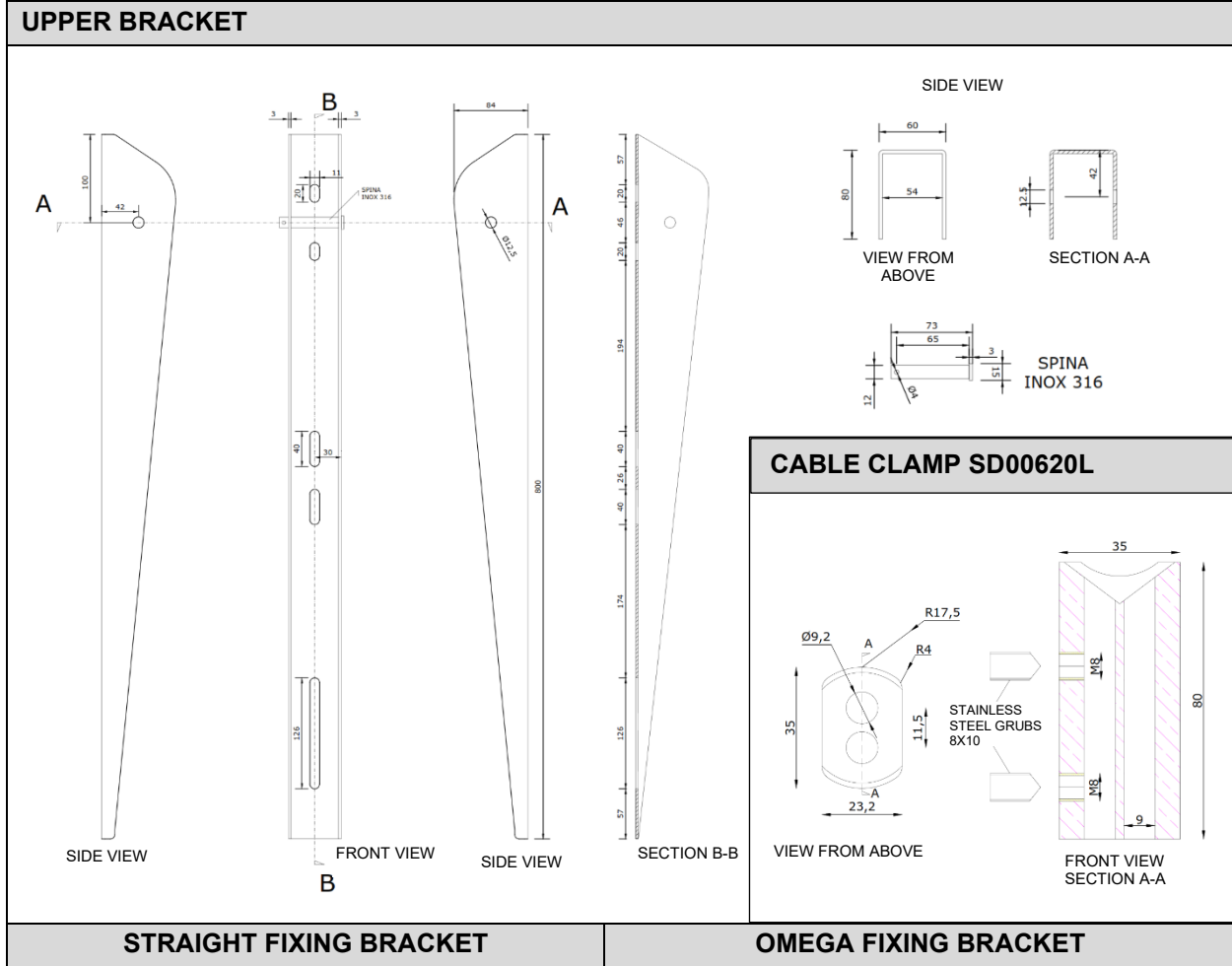

### STRAIGHT FIXING BRACKET

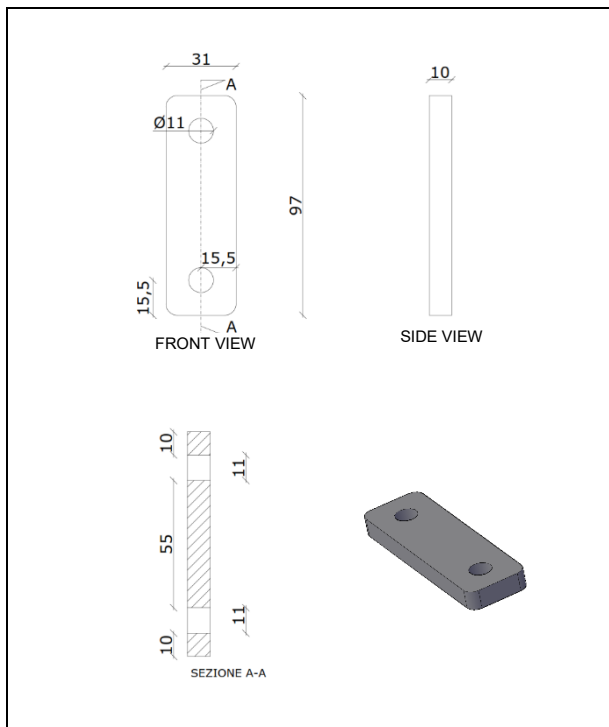

### OMEGA FIXING BRACKET

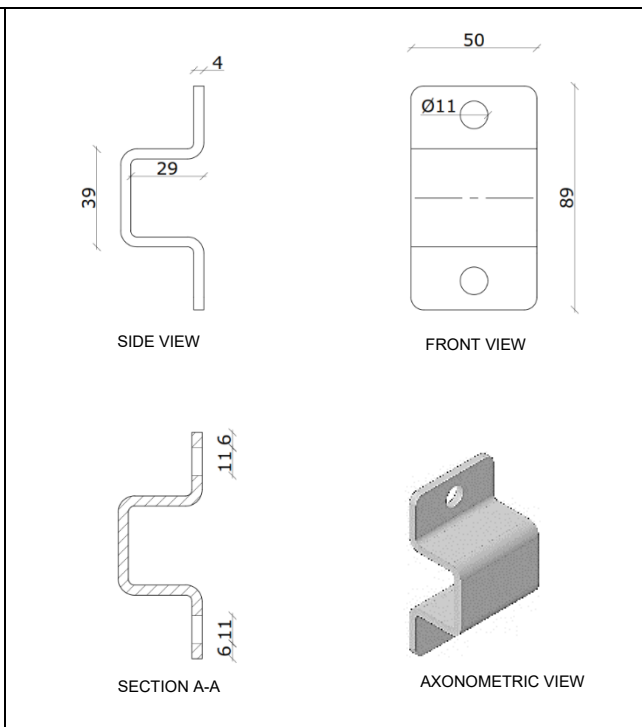

Table 5.1 – Upper Anchorage Technical Data Sheets

### 8.4 Upper anchorage with outreach section

Upper fixing element with outreach section, in AISI 304 stainless steel and 6082 aluminium, for rigid vertical anchor line.

The element consists of:

1) One 6082 (4.a) aluminium outreach track length 2.00 m.

The profile has a height H of 52 mm and a base B of 51.6 mm. On the profile are 6 slotted holes (two of them 11x20 mm, two 11x40 mm and the last one 11x126 mm) for fixing to the ladder (4.b) through special stainless-steel components (M10 bar, M10 self-locking nut, M10 washer, straight locking bracket on SLSDFSTDR rung and SLSDFANSB outreach core).

In the upper part is a slotted hole 11.3x30.3 mm for fixing the upper aluminium element 6082 (4.c). This part consists of an SLSDFSTSB outreach bracket, attached to the track profile with an SLSDFTASF threaded plug and SLSDFTASP loop, in which the rope of the vertical anchor line will be fixed through a special cable clamp.

2) A cable clamp kit (4.d) in AISI 316 STAINLESS steel for the adjustment of the free end of the rope, tailored to the ladder + outreach section.

The kit consists of an element to end the cable with entry hole diameter 19.2 mm and component length 60 mm. A split pin part screwed onto the cable header element serves to secure the vertical line cable to the upper anchor point.



4.a

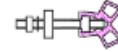

4.b



4.c



4.d

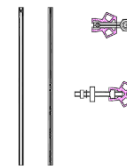

Upper anchorage with outreach section

CODE	DESCRIPTION	DIMENSIONS [mm]	WEIGHT [kg]
SDFESB2	OUTREACH ELEMENT Outreach track 2.00 m + ladder fixing components + upper anchorage	51.6x52XL2000	5.35
SDFSERP	Cable Clamp for Outreach Track		0.30

Table 6 – Description of upper anchorage with outreach section

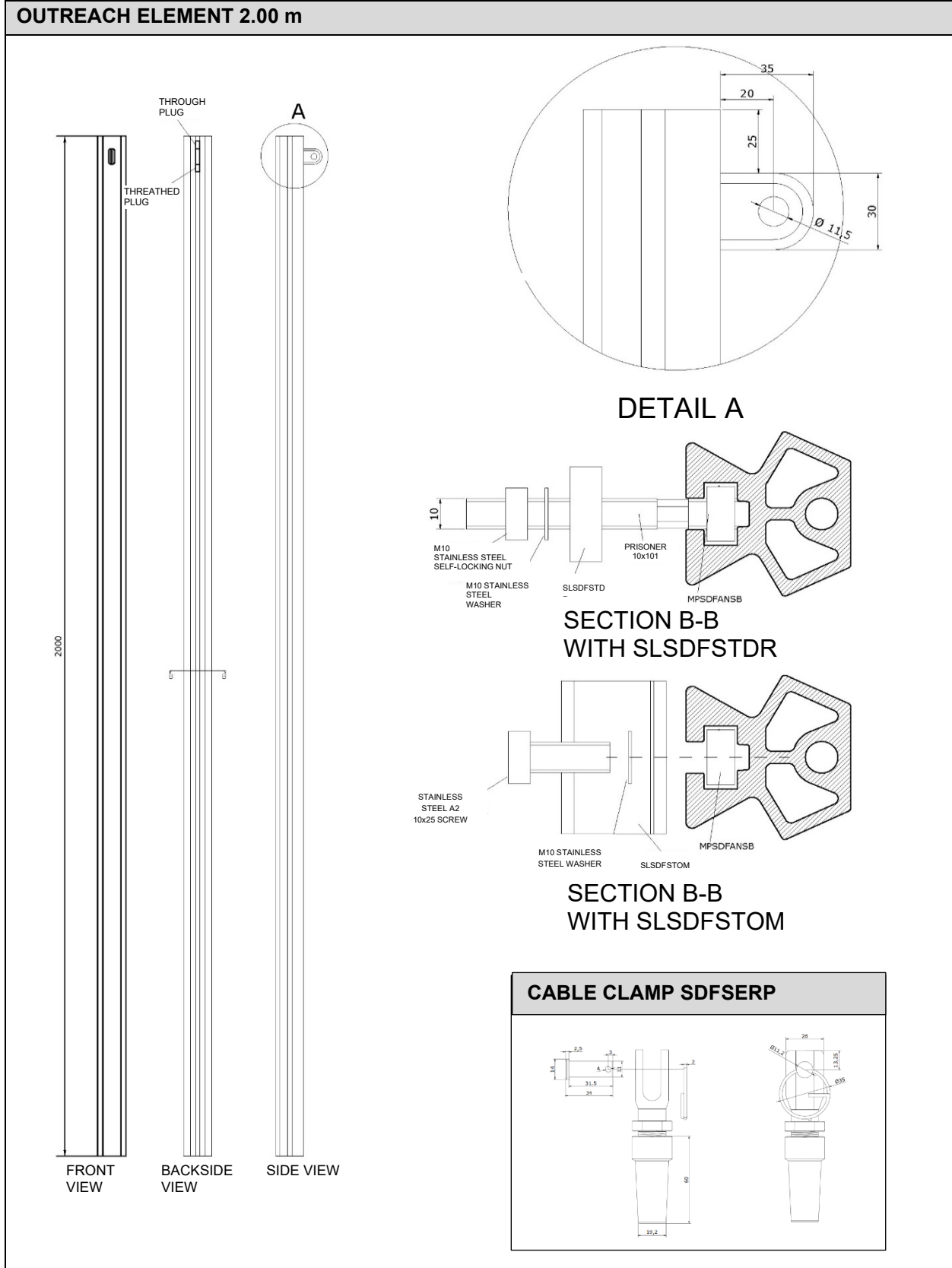
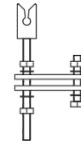

Table 6.1 – Technical data sheet Upper anchorage with outreach

### 8.5 Intermediate element

Intermediate element, in AISI 304 stainless steel and 6082 aluminium, for rigid vertical anchorage line to be inserted when exceeding 10 m. The element consists of a 6082 aluminium intermediate body of dimensions 45x50x25 mm with a 10 mm diameter hole into which the 8 mm diameter rope of the vertical line must be inserted. The intermediate block is fixed to the ladder by means of M10 bar, M10 self-locking bolts, M10 washers, M10 hex head screw and straight fixing brackets.

5.



CODE	DESCRIPTION	DIMENSIONS [mm]	WEIGHT [kg]
SDFEINT	Intermediate for vertical line	45x50x25	0.10

Table 7 – Description of Intermediate Element

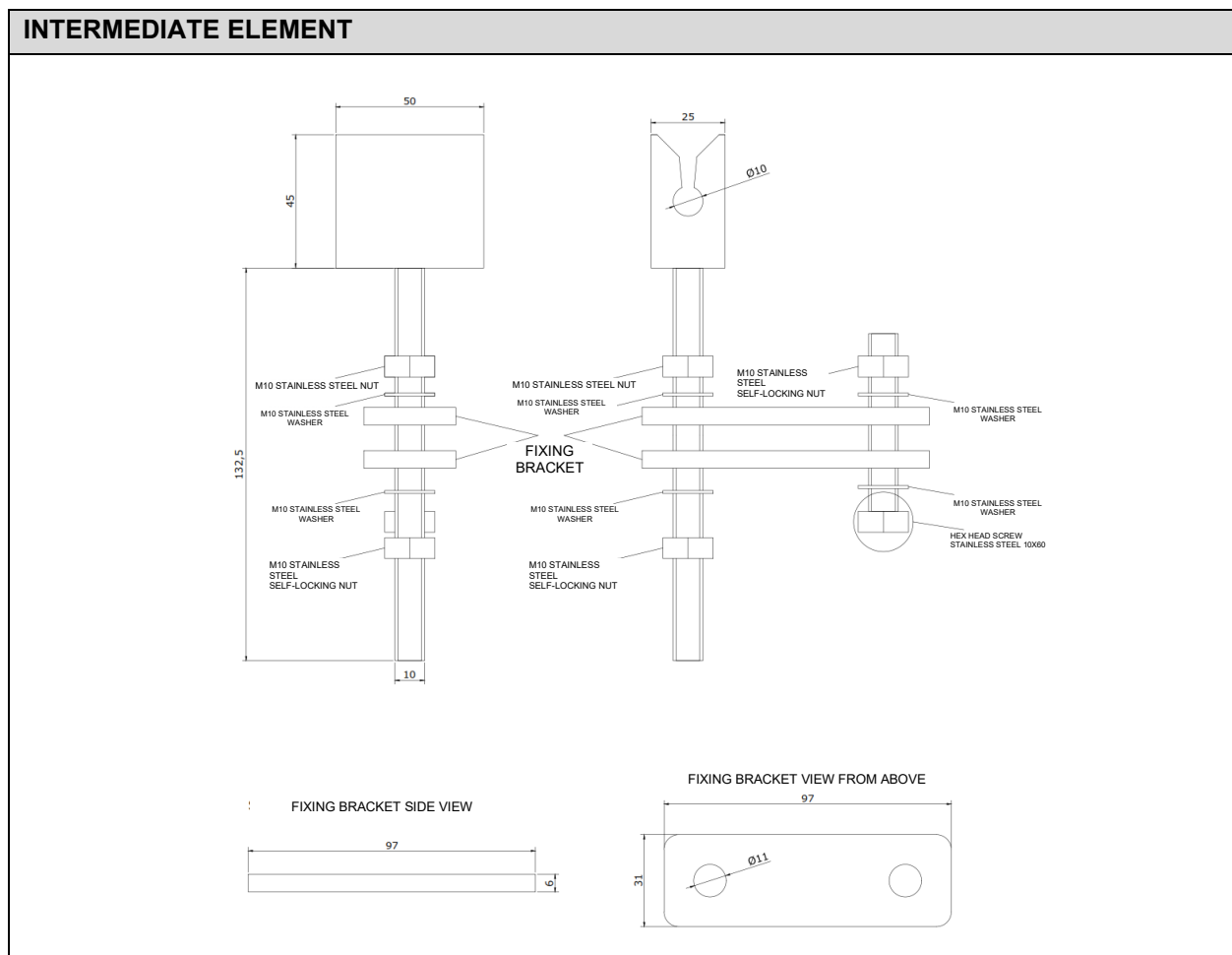

Table 7.1 – INTERMEDIATE ELEMENT technical data sheets

## 8.6 CABLE

<p>Stainless steel cable AISI 316 with 8 mm rated diameter composed of 7 strands each of 7 wires.          A tensile strength equal to 36 kN.          The cable is supplied with the two free ends, one must be inserted into the tensioner with tightening of the built-in cable and the other to be repaired during installation by means of a cable clamp.          Identification and traceability of the product: to support the high quality and tightness of the cable, there is a label marked Sicur Delta.</p>				6.	
CODE	DESCRIPTION	DIMENSIONS [mm]	WEIGHT (kg/m)		
SDFCAVO	LINEAR METER CABLE Φ 8 mm 7x7 AISI 316	8 mm	0.23		

Table 6 – Cable Description

## 8.7 FIXING SCREWS

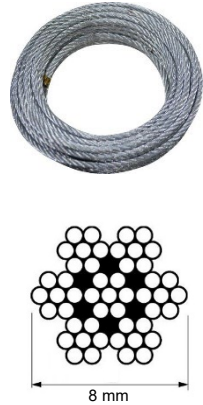

v1 (10X60) A2-70 STAINLESS STEEL		v2 NUT and WASHER	
<ul style="list-style-type: none"> <li>Hex head screw 10x60 for fixing brackets</li> </ul>		<ul style="list-style-type: none"> <li>M10 Screw Nut</li> </ul> 	<ul style="list-style-type: none"> <li>Washer M10</li> </ul> 

Table 7 – Description of the fixing screws for mounting the rigid line SDFLEX

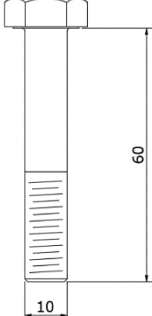

# EU DECLARATION OF CONFORMITY

This EU declaration of conformity is issued under the sole responsibility of the manufacturer:

**SICUR DELTA SRL – Via A. Vespucci 16, 56029 S. Croce sull'Arno (PI) - Italy**

It is hereby declared that, for all manufacturing batches, the following PPE  
(Personal Protective Equipment)

**SDFLEX**  
**Guided Type Fall Arrester Including a Rigid Anchor Line**

complies with the provisions of Regulation (EU) 2016/425  
and relevant harmonised European legislation  
**EN 353-1:2014+A1:2017**

whose EU type-examination (form B) was carried out by the following notified body

**QUINTIN CERTIFICATIONS**  
**NOTIFIED BODY N° NB 2927**

Issuing the following EU type-examination certificate

**N° 2927/4805/160/08/23/0014**

---

The PPE is subject to the conformity assessment procedure based on internal production control plus supervised product checks at random intervals (form C2) under the supervision of the following notified body

**QUINTIN CERTIFICATIONS**  
**NOTIFIED BODY N° NB 2927**

S. Croce sull' Arno, 21/08/2023  
Representative

The Legal

 SICUR DELTA  
Sicur Delta S.r.l.  
VIA AMERIGO VESPUCCI, 16  
56029 - S. CROCE SULL'ARNO (PI)  
C.F./P.IVA 05138810489  
TEL +39 0571 367599 FAX +39 0571 367599  
PER ACCETTAZIONE









**SICUR DELTA**

Masters of Craft

**SICUR DELTA SRL CON SOCIO UNICO**

Via Amerigo Vespucci, 16  
26029 – Santa Croce sull'Arno (PI)  
TEL. +39 0571 33588 / 367677 FAX +39 0571 367599  
VAT 05738810489 - SDI T04ZHR3  
[www.sicurdelta.it](http://www.sicurdelta.it) - [info@sicurdelta.it](mailto:info@sicurdelta.it)